



RDM-U 系列欧化干燥机采用下吹风式结构, 热风分散均匀, 并且桶体采用双层保温, 减少空气与桶内的热能交换, 干燥能耗比普通料斗式干燥机低, 内外层均采用全不锈钢制造, 外表美观, 特别适合搭配除湿机来对工程塑胶的干燥。

RDM-U series European Standard dryer use air down-blowing design, the hot wind are distributed evenly barrel body adopts double layer insulation, reduce heat exchange between air and barrel, lower drying energy consumption than ordinary hopper dryer, inner and outer layers are made of stainless steel, polished apperance, especially suitable with dehumidifier drying the engineering plastics.

配带视窗清理门, 方便观察以及清理桶内塑料。
Equipped with window cleaning door for easy observation and Clean the plastic in the barrel.

配地上支架, 也可以选配干燥机底座, 直接安装于注塑机上。
Equipped with Stents on the ground, can also choose a dryer base, install directly on the injection molding machine.

RDM600U以下机型配移动脚轮, 可随时移动到所需位置。
RDM600U following model equipped with movable casters can move to the desired position at any time.

内外双层保温, 且全不锈钢材质, 外表美观。
Inside and outside double layer insulation, all stainless steel material, beautiful appearance.

液晶显示屏, 可显示温度数值小至数点后一位, 温控精度±1度, 可实时查询故障原因。
Liquid crystal display screen, display temperature value to one decimal place, temperature control accuracy is plus or minus 1 degree. Can query the cause of the fault in real time.

底部配置吸料盒, 可连接吸料机送料至注塑机。
The bottom equipped with material suction hopper can connect the loader to the injection molding machine.

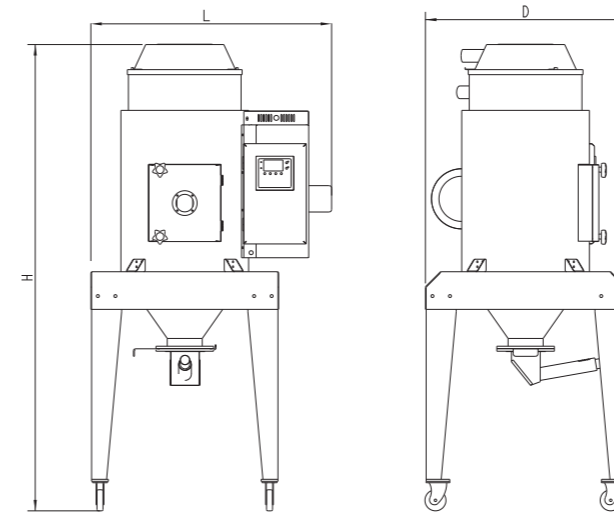

RDM38U~RDM600U

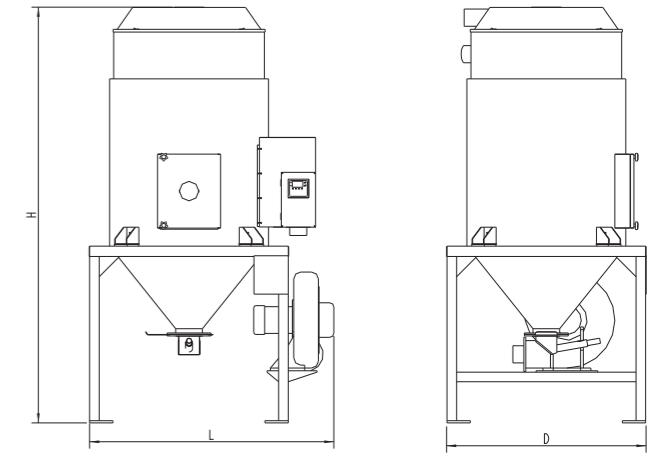

RDM750U~RDM3000U

规格表 Specifications

机型 Model	保温料斗容量 Drying hopper capacity	干燥电热 Dryer power	风机功率 Blower power	外形尺寸(LxWxH) External size	风管尺寸 Air duct size	重量 Weight
	L	kw	w	mm	inch	kg
RDM-38U	38	3	135	700x700x1500	2	50
RDM-80U	80	4	155	830x800x1600	2	60
RDM-120U	120	4	155	960x800x1800	2	80
RDM-160U	160	5.5	210	1000x800x1820	2.5	100
RDM-230U	230	6	215	1050x1000x2020	2.5	120
RDM-300U	300	12	320	1150x900x2100	3	150
RDM-450U	450	15	320	1250x1000x2220	3	180
RDM-600U	600	18	340	1300x1200x2520	4	230
RDM-750U	750	20	340	1400x1200x2550	4	300
RDM-900U	900	22	1030	1480x1220x2500	5	450
RDM-1200U	1200	27	2200	1480x1220x2900	5	520
RDM-1500U	1500	32	3000	1780x1450x3030	5	720
RDM-2000U	2000	32	3000	1830x1500x3380	6	820
RDM-2500U	2500	58	5500	2040x1800x3810	6	880
RDM-3000U	3000	58	5500	2200x1800x3810	6	950
RDM-5000U	5000	80	11000	2260x2200x5000	8	1400
RDM-6000U	6000	126	15000	5200x1950x1950	10	1600

Note 注:

- 1) 机器电压规格为3Φ, 380V, 50Hz。
- 2) 可以根据要求变更。

- 1) The machine voltage specification is 3Φ, 380V, 50Hz.
- 2) The voltage can be changed as you require.

可选配件 Optional spare parts



磁力底座
Magnetic Base



热风回收装置
Hot wind recovery equipment

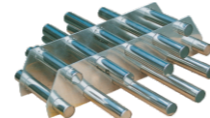

磁力架
Magnetic frame

